

GAMA SONIC[®]
SOLAR LIGHTING

2025

TABLE OF CONTENTS

Gama Sonic® - Who we are	3
Why Breakthrough Technology Matters	4
Commercial Series By Gama Sonic®	6
Centennial Commercial Solar LED Post Light	8
Modern Commercial Solar LED Post Light	10
Denali Commercial Solar LED Post Light	12
Contemporary Square Solar Post Light - Commercial Edition	14
Imperial III Commercial Solar Post Light	16
Everest II Commercial Solar Lamp	18
Solar Pillar Commercial Bollard	19
Vantage Bollard Solar Pathway Light	19
Plaza Solar Light	20
Solar Security & Area Light	21
Residential Series by Gama Sonic®	22
Victorian Morph Solar Light	24
Victorian Bulb Solar Light	25
Aria Solar Light	26
Royal Bulb Solar Light Brushed Bronze	28
Royal Bulb Solar Light Black	30
Royal Bulb Solar Light Weathered Bronze	31
Polaris Solar Light	32
Baytown II Bulb Solar Lamp	33
Grand Prairie Bulb Solar Light	34
Pagoda Bulb Solar Lamp	35
Orion Solar Light	36
Aspen Solar Light	37
Imperial Trio Bulb Solar Post Light	38
Halo Solar Post Light	39
Contemporary Square Solar Post Light	40
Eclipse Downlight Solar Wall Light	42
Eclipse Backlight Solar Wall Light	43
Cottage Solar Barn Light	44
Carriage Solar Barn Light	45
Modern Farmhouse Solar Wall Light	46
Novaedge Solar Light	47
Solar Coach Lantern	48
Solar Address Wall Plaque Light	48
Architectural Solar Wall Accent Light	49
Contemporary Square Solar Path Light	50
Sentry Modern Pathway Light	51
Solar Garden Light Shepherd Hook	52
Tri-Color Progressive Solar Spotlight	53
Dual Color Solar Flood Light	53
Luxor Stainless Steel Bollard Solar Light	54
Luxor Solar Pathway Light	54
Luxor Solar Post Cap Light	55

Gothic Solar Post Cap Light	56
Luna II Solar Post Cap/Pier Mount Light	57
Bulbs	58
Batteries	58
Accessories	58
Posts	59

Who We Are

Gama Sonic® is the world leader in upscale, high quality solar lighting for homes, businesses and outdoor spaces. We develop, manufacture and market residential and commercial/industrial grade, energy-efficient outdoor solar powered lighting products. Since 2001, our multiple patented technologies have introduced innovative and cost-effective outdoor solar lighting solutions that provide unsurpassed levels of illumination and reliability. Gama Sonic® distributes products around the globe.

OUR MISSION

Our singular mission is to provide a solar solution for replacing traditional gas and electrical fixtures with an equivalent look, quality, duration and brightness. Gama Sonic® Solar lights can be easily installed anywhere outdoors without any electrical wiring, trenching or digging, and most importantly, without compromising performances of traditional lighting.



Our Story

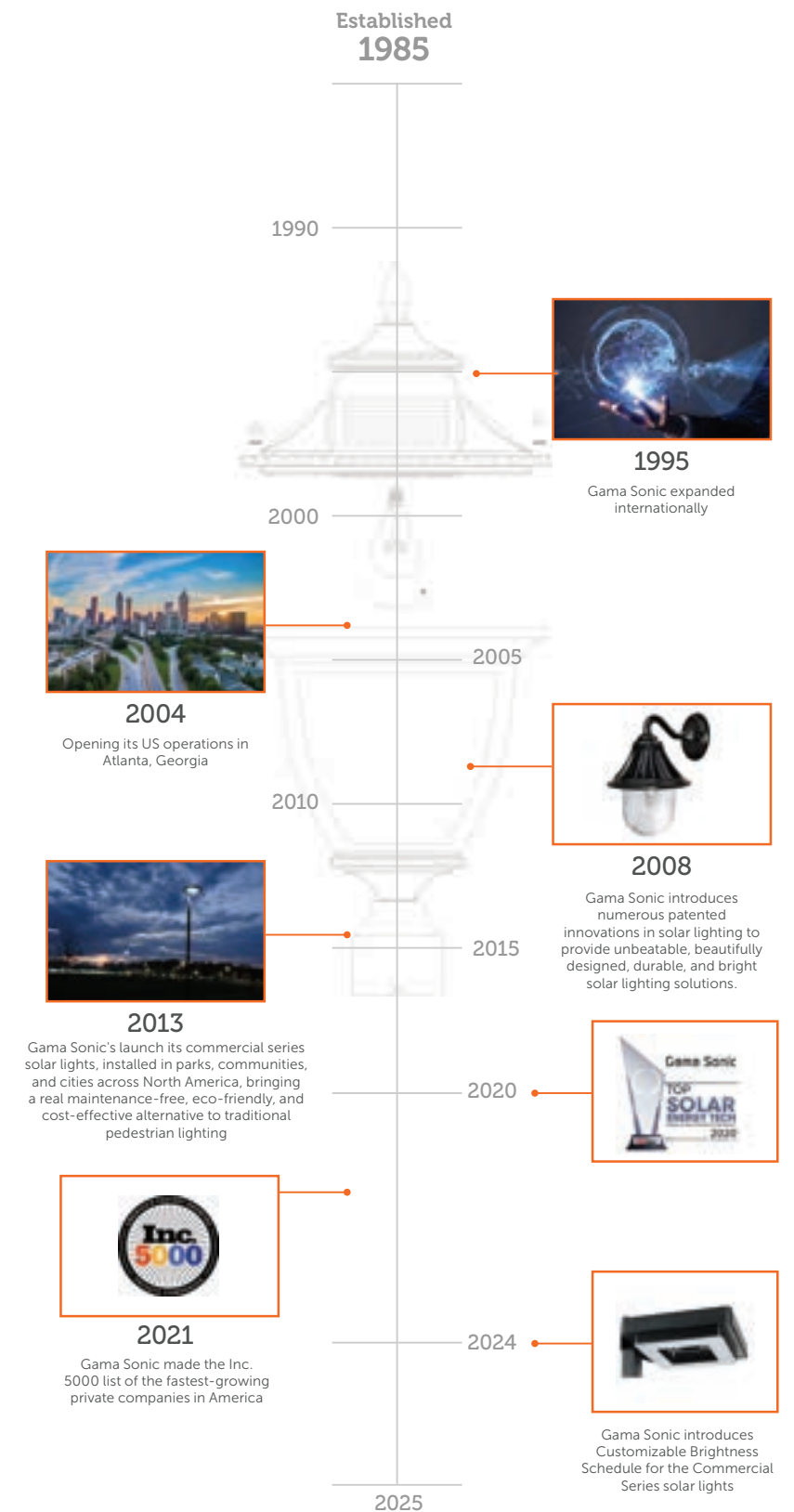











Why Breakthrough Technology Matters

Over Twenty (20) Design and Utility Patents

No matter what outdoor lighting challenges you face, choosing a technology-rich solution makes all the difference. Solar-powered products have been around for years, but it took the research and development expertise of Gama Sonic® engineers to create rechargeable solar lighting designs that outshine and outlast every major competitor. We stay ahead of the design curve by creating and testing products that fit a wide variety of residential and commercial applications.

What this means to you: Enjoying a safer, more reliable, and more cost-effective investment for your lighting budget.

 LED Technology	 Easy Installation	 No Wiring
 Weather Resistant	 Maintenance Free	 Cost Efficient
 Eco Friendly	 2 Year Warranty (Residential Products)	 5 Year Warranty (Commercial Products)



GS Cone Technology is a patented technology which allows our solar lamps to disburse more light efficiently and spreading the directional LED rays down and around the light fixture.

Patent #7172307



Morph Solar Panel Technology is our ground-breaking process of capturing more power from the sun. Monocrystalline solar cells are molded to the surface of the lamp, "morphing" the lamp into a solar panel.



Translucent Solar Panel (TSP) is an industry changing technology that transforms the largest surface areas of the light fixture into solar panels - the glass panes. This innovative technology embeds the solar cells into the glass, maximizing the power from the sun.



Automatic Tracking System (ATS) technology is revolutionizing the way to maximize the sun's rays in charging solar lights. This technology, previously used in large solar farms, is now available to the consumer to track the sun throughout the day and provides a longer lasting and brighter light.



GS Solar LED Light Bulb is a patented technology that replicates the conventional look and feel of the traditional bulb in outdoor solar-powered lamps.

Patent #9458970



LuminCore Technology is our latest technology, meticulously engineered to illuminate your space with precision. Featuring strategically placed 24 LEDs in a pyramid formation, this innovative design ensures consistent illumination from all directions, mimicking the light distribution of a standard bulb while offering a sleeker, modern aesthetic.

Commercial Series by **GAMA SONIC®**

Since 2013, Gama Sonic's Commercial Series line has been installed in parks, communities and cities across North America, bringing a real maintenance-free, eco-friendly, and cost-effective alternative to traditional pedestrian lighting.

▶ Scan to Learn More



Our Partners:





Centennial Commercial Solar LED Post Light

- Commercial grade construction
- Coastal approved
- IP65 - weather resistant rating
- 64 SMD LEDs
- Corrosion resistant powder-coated cast aluminum
- 22W tempered glass SunPower™ solar panel
- Exterior low/off/high switch
- Automatic dusk to dawn operation
- Patent #7172307

1000
LUMENS

4-8
NIGHTS
DURATION

3X
LIFEPO4 batteries
GS12_8V60
GAMA SONIC
BATTERY

IMPROVED BRIGHTNESS



100012
3" Fitter



Customizable Brightness Schedule: Dynamic timing and brightness settings to meet your needs (adapts smartly to changing night durations) - Available For Special Order

▶ Scan to Learn More

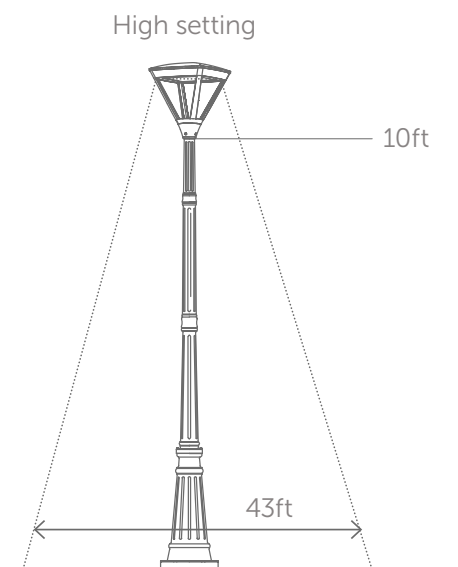

*Beam diameter is based on quantity of illumination [IES Recommended Light Levels] RP-8-18 for Walkways/Bikeways of a minimum 0.2 Foot Candle.

The Centennial Solar Light is a commercial grade, high-performance solar lamp providing a stunning 1000 lumens of bright white (6000K) light for up to 8 nights. This solar lamp's weather resistant, coastal approved construction is perfect for commercial and residential areas such as pedestrian walkways, parking lots, and community parks. The Centennial Solar Light is the practical solution for any outdoor lighting application.

Part #	Dimensions	UPC	Wgt	LED Color	Lamp Color
100012	18.5L x 18.5W x 20H	859641007240	30	Bright White (6000K)	Black
100012-5	Available by Special Order – Contact Us for Details			Warm White (2700K)	Black

*Posts sold separately in all above models



The unique, contemporary style of the Modern Commercial Grade Solar Post Light makes it perfect for any outdoor space, especially parks, commercial grounds, and residential communities. It fits standard 3" posts and is an excellent choice for replacing and retrofitting outdated gas or traditional electric lights. The light turns on automatically from dusk until dawn and, for added versatility, allows you to choose between a high or low output at the flip of a switch.

Modern Commercial Solar LED Post Light

- Commercial grade construction
- Coastal approved
- IP65 - weather resistant rating
- 24 SMD LEDs
- Corrosion resistant powder coated cast aluminum
- Powered by efficient monocrystalline solar panel
- Exterior low/off/high switch
- Automatic dusk to dawn operation
- 140° Detection zone
- 2 modes of operation: PIR / Constant On
- 20W tempered glass solar panel
- Timer feature allows 4-8 hours of duration or dusk to dawn operation



Customizable Brightness Schedule: Dynamic timing and brightness settings to meet your needs (adapts smartly to changing night durations) - Available For Special Order

Scan to Learn More

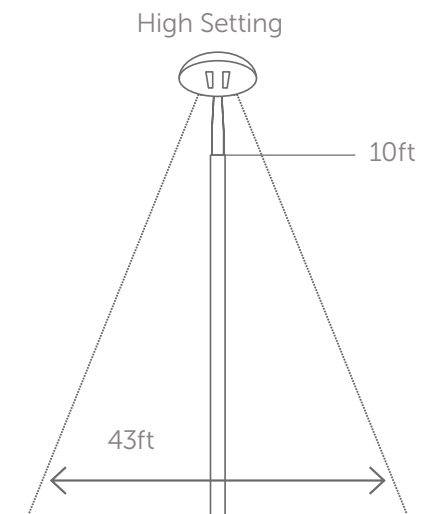

*Beam diameter is based on quantity of illumination [IES Recommended Light Levels] RP-8-18 for Walkways/Bikeways of a minimum 0.2 Foot Candle.

Part #	Dimensions	UPC	Wgt	LED Color	Lamp Color
102IST60012	19.5L x 19.5W x 28H	859641008261	24.6	Bright White (6000K)	Black

*Posts sold separately in all above models



Gama Sonic's Denali is a commercial grade pedestrian lighting featuring Gama Sonic's exclusive Morph Technology where the solar panels are morphed into the light fixture for more powerful solar charge and longer light output. Mount the Denali as a single head or double head, this beautifully designed solar post light can be used to illuminate parks, communities, sidewalks, and campgrounds.

Denali Commercial Solar LED Post Light w/ Timer

- Commercial grade construction
- 33 SMD LEDs
- IP65 - weather resistant rating
- Powered by efficient monocrystalline solar panels
- Morph Technology
- Automatic dusk to dawn operation
- UV inhibited polycarbonate weather resistant lamp head
- Powder coated cast-aluminum weather resistant structure
- 26W solar panel
- Timer feature allows 4-8 hours of duration or dusk to dawn operation

600
LUMENS

3-6
NIGHTS
DURATION

2X 
GS32V12A
GAMA SONIC
BATTERY

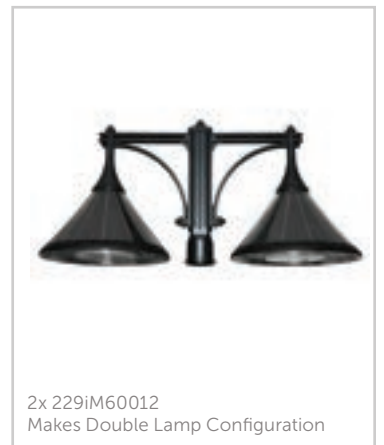

4,5,6,7,8 hours duration or 0 for dusk to dawn operation



Customizable Brightness Schedule: Dynamic timing and brightness settings to meet your needs (adapts smartly to changing night durations) - Available For Special Order

 Scan to Learn More

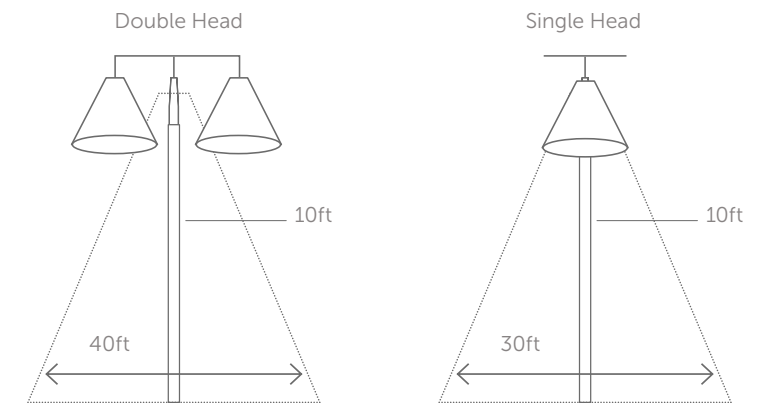

*Beam diameter is based on quantity of illumination [IES Recommended Light Levels] RP-8-18 for Walkways/ Bikeways of a minimum 0.2 Foot Candle.

Part #	Dimensions	UPC	Wgt	LED Color	Lamp Color
229iM60012	23.125 L x 16.5W x 19.875H	859641008292	13	Bright White (6000K)	Black

*Posts sold separately in all above models

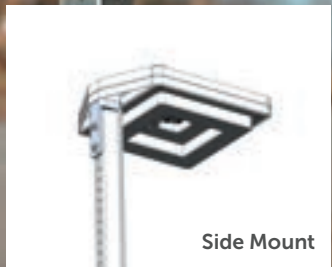

Introducing Gama Sonic's Contemporary Square Solar Lamp Post Commercial Edition, specially designed for bus stop sign lighting, featuring a special dynamic 25/50/25 brightness schedule and versatile mounting bracket design to fit common U-Channel and Square sign posts. Lamps can also be used in other urban, commercial or industrial areas where practical and cost-effective lighting is needed.

Contemporary Square Solar Post Light - Commercial Edition

- Powered by efficient monocrystalline solar panels
- Automatic Dusk to Dawn operation, featuring a special dynamic 25/50/25 brightness schedule: Automatically adjusts brightness levels throughout the night—starting at full brightness for the first 25%, transitioning to low brightness for the middle 50%, and returning to full brightness for the final 25% of the night—while adapting seamlessly to seasonal changes
- Corrosion resistant powder coated cast aluminum
- 3 color temperature options: Warm White (3000K) / Natural White (4000K) / Bright White (5000K)
- 14W tempered glass solar panel
- 2 mounting options: center mount and side mount, versatile mounting bracket design to fit most common U-Channel and Square sign posts.

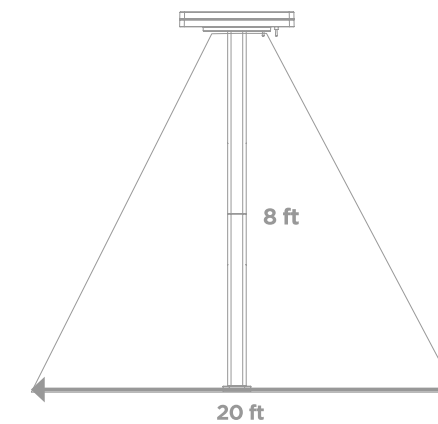
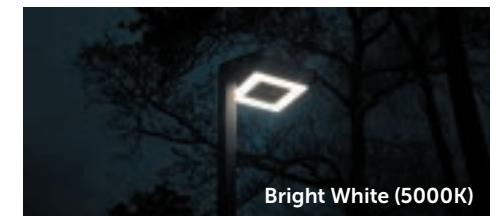

Part #	Dimensions	UPC	Wgt	LED Color	Lamp Color
217IX20012	15L x 12.25W x 5H	185455000536	8.4	Warm White (3000K) + Natural White (4000K) + Bright White (6000K)	Black

*Posts sold separately in all above models



The Imperial III Solar Light is a commercial grade solar lamp featuring both a warm-white (2700K) and bright white (6000K) light temperature, provided at a brilliant 300/600/900 lumens and for up to 6 nights (300 lumen per lamp). Continuing the Imperial series reputation for durability, functionality and style, its weather resistant construction is perfect for commercial and residential areas such as pedestrian walkways, parking lots, and community parks.

Imperial III Commercial Solar Post Light

- Commercial grade construction
- 21 SMD LEDs
- Dual color - bright white/warm white
- Automatic dusk to dawn operation
- Powered by efficient monocrystalline solar panels
- Powder coated cast-aluminum weather resistant structure
- Beveled glass panes
- Patent #7172307
- 8W tempered glass solar panel

300
LUMENS

3-6
NIGHTS
DURATION

4X 
GS32V30
GAMA SONIC
BATTERY

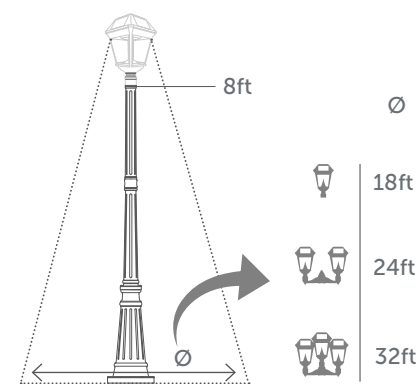
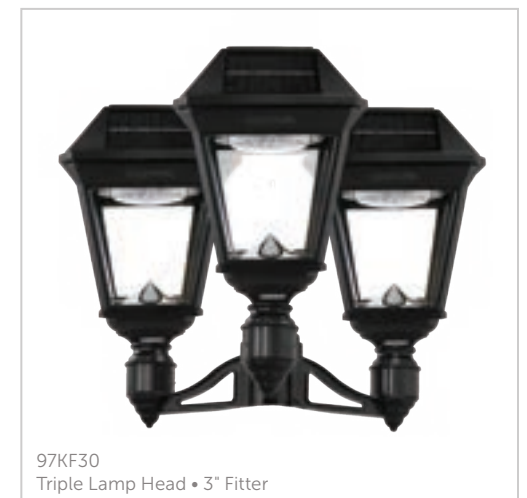

*Beam diameter is based on quantity of illumination [IES Recommended Light Levels] RP-8-18 for Walkways/Bikeways of a minimum 0.2 Foot Candle.

Part #	Dimensions	UPC	Wgt	LED Color	Lamp Color
97K012	10.5L x 10.5W x 19.5H	859641007462	9.4	Bright White (6000K) + Warm White (2700K)	Black
97KF20	30L x 10.5W x 21.5H	859641007639	21.2		
97KF30	26.5L x 24.5W x 21.5H	859641007646	31.2		

**Posts sold separately in all above models*

Everest II Commercial Solar Lamp



- Commercial grade construction
- Automatic dusk to dawn operation
- Powered by efficient monocrystalline solar panel
- Cast-aluminum all weather-resistant structure with UV protection
- Exterior low/off/high switch
- Acrylic lens
- Patent #9458970
- 10W tempered glass solar panel

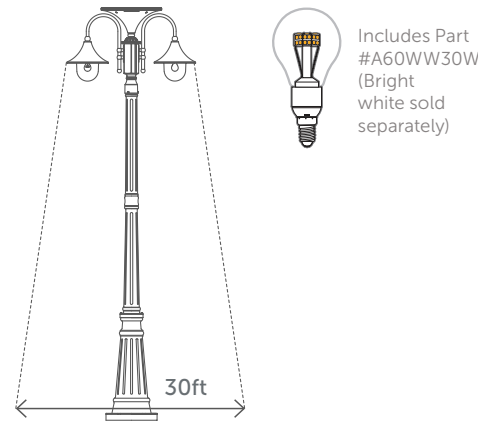
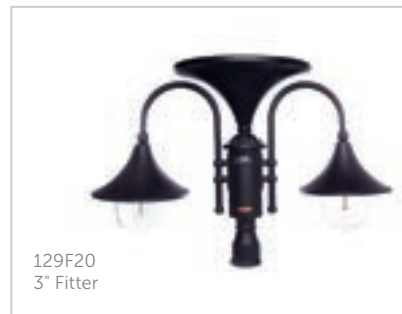

*Beam diameter is based on quantity of illumination [IES Recommended Light Levels] RP-8-18 for Walkways/Bikeways of a minimum 0.2 Foot Candle.



500
LUMENS

5-10
NIGHTS
DURATION

GS37V27A
GAMA SONIC
BATTERY

Part #	Dimensions	UPC	Wgt	LED Color	Lamp Color
129F20	Available by Special Order – Contact Us for Details			Warm White (2700K)	Black

*Posts sold separately in all above models

Solar Pillar Commercial Bollard

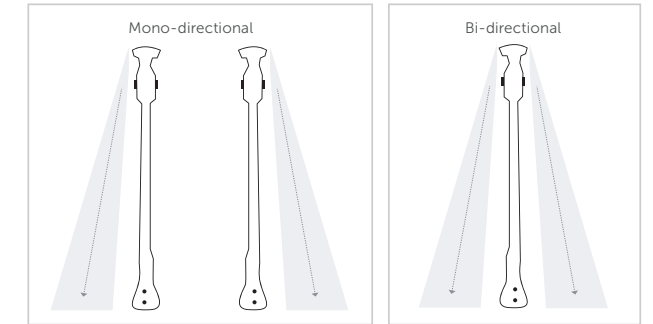

- Bifacial solar panel technology
- 2 modes of operation: PIR 150 cycles/constant on mode with dusk to dawn operation
- Cast-aluminum weather resistant structure
- Bi-directional or mono-directional Light output
- 19W tempered glass solar panel

500
LUMENS

up to 2
NIGHTS
DURATION

GS64V60
GAMA SONIC
BATTERY

Part #	Dimensions	UPC	Wgt	LED Color	Lamp Color
9iD50800	8.75L x 3.5W x 31.25H	859641007851	11	Warm White (3000K)	Black

Vantage Bollard Solar Pathway Light



- Powered by efficient monocrystalline solar panels
- Automatic dusk to dawn operations
- Cast-aluminum weather resistant structure
- Patents #9458970, #7172307
- 4.5W tempered glass solar panel
- 2 installation mounting option included: flat mount and stake mount
- Turtle-safe bulbs available



200
LUMENS

up to 3
NIGHTS
DURATION

3X GS32V30
GAMA SONIC
BATTERY

Part #	Dimensions	UPC	Wgt	LED Color	Lamp Color
314B50000	10.25L x 10.25W x 31.25H	859641008407	4.4	Warm White (2700K)	Black

Plaza Solar Light



- Morph technology
- Powered by efficient monocrystalline solar panels
- Automatic dusk to dawn operation
- UV inhibited polycarbonate lamp head
- Powder coated cast-aluminum structure
- Rigid ABS resin weather resistant structure
- Cast-aluminum mounting arm/bracket
- Exterior low/off/high switch
- Patent #9458970
- 8W solar panel

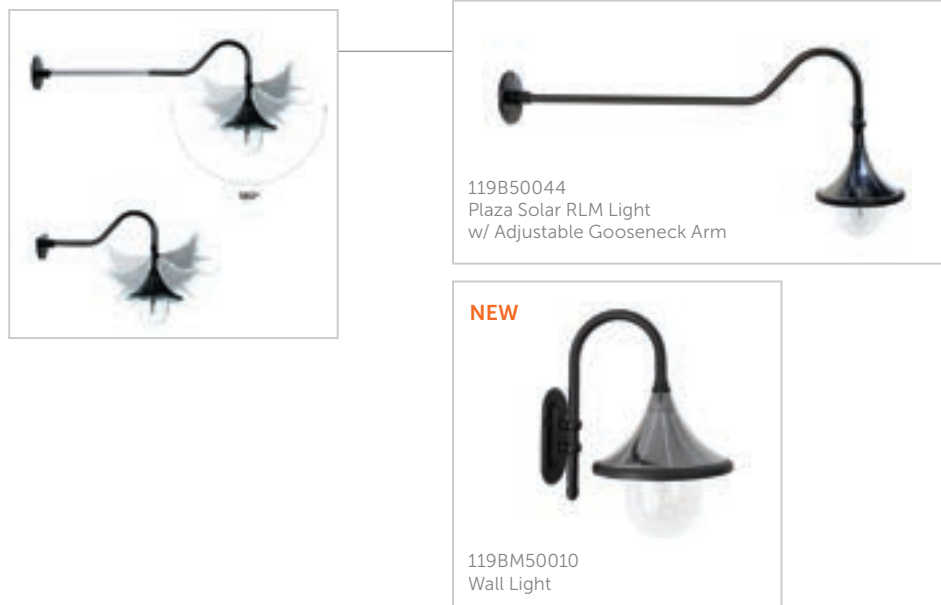

180 LUMENS

2 NIGHTS DURATION

2X GS32V30 GAMA SONIC BATTERY

119BM50010 Includes Part #A60WW20W (Bright white sold separately)

119B50044 Includes Part # A60WW20W-DIR



Part #	Dimensions	UPC	Wgt	LED Color	Lamp Color
119B50044	11L x 42W x 21H	859641007356	10.12	Warm White (2700K)	Black
119BM50010	13.88L X 10.63W X 17.75H	859641007950	5.4		

Solar Security & Area Light with Motion Sensor and Timer

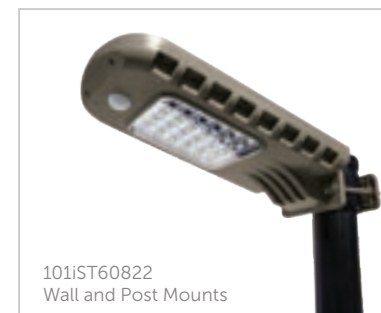

101iS60822 Wall and Post Mounts

- 810 Lumens (as Security Light)
- 100 Cycles (as Security Light)
- 270 Lumens (as Area Light)
- Up to 1 nights duration (as Area Light)
- GS37V60 Battery
- 4W tempered glass solar panel



201iS60822 Wall and Post Mounts

- 1620 Lumens (as Security Light)
- 150 Cycles (as Security Light)
- 500 Lumens (as Area Light)
- Up to 2 nights duration (as Area Light)
- GS37V16A Battery
- 10W tempered glass solar panel



301iS60822 Wall and Post Mounts

- 2800 Lumens (as Security Light)
- 150 Cycles (as Security Light)
- 980 Lumens (as Area Light)
- Up to 2 nights duration (as Area Light)
- GS32V24A Battery
- 16W tempered glass solar panel

- IP65 - weather resistant rating
- Durable ABS resin housing
- Timer Feature

Integrated PIR motion sensor

PIR/OFF/ON SWITCH

PIR Mode: Light turns on when motion is detected
On Mode: Constant on

TIMER

4,5,6,7,8 hours duration or 0 for dusk to dawn operation

Part #	Dimensions	UPC	Wgt	LED Color	Lamp Color
101iS60822	12L x 6W x 2H	859641008223	2	Bright White (6000K)	Dark Grey
201iS60822	20L x 8.5W x 2H	859641007837	5.5		
301iS60822	22.50L x 10.25W x 4H	859641008346	11.10		

Residential Series by **GAMA SONIC®**

Gama Sonic's Residential series solar lights can upgrade your home's curb appeal while using renewable energy from the sun to illuminate your home's outdoor areas. We help homeowners achieve a notable exterior home upgrade with very little effort or cost, inviting them to give their home an impressive, yet quick and easy facelift with upscale solar lighting.

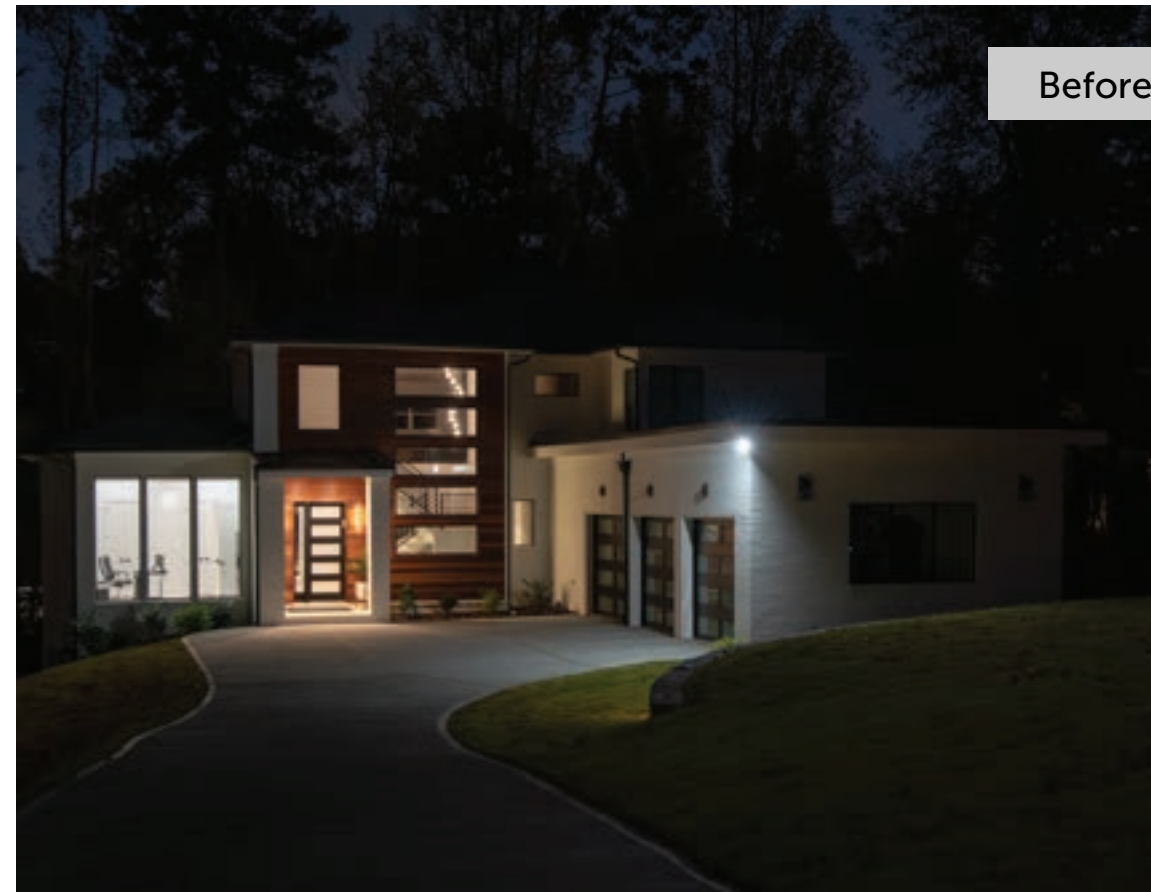

Before & After



Before & After



Victorian Morph Solar Light



- Powered by efficient monocrystalline solar panels
- Morph Technology
- Automatic dusk to dawn operation
- Cast-aluminum weather resistant structure
- Beveled glass panes
- Patents #7172307, #9458970
- 5.4W solar panel

150
LUMENS

up to 2
NIGHTS
DURATION

2X
GS32V30
GAMA SONIC
BATTERY

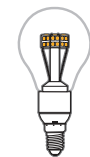

Includes Part
#C37WW10W
(Bright white sold
separately)

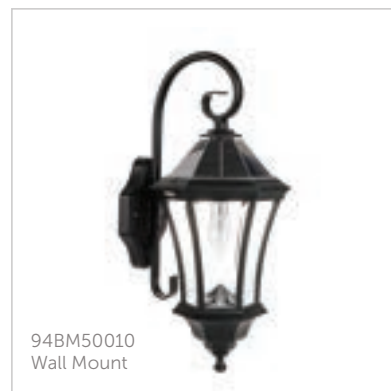

Part #	Dimensions	UPC	Wgt	LED Color	Lamp Color
94BM50010	11.375L x 9.25W x 21.25H	859641008247	10	Warm White (2700K)	Black
94BM500D2	10.25L x 25.25W x 99.75H	859641008230			

Victorian Bulb Solar Light



- Powered by efficient monocrystalline solar panels
- Automatic dusk to dawn operation
- Cast-aluminum weather resistant structure
- Exterior low/off/high switch
- Beveled glass panes
- Patents #7172307, #9458970
- 2.4W tempered glass solar panel

150
LUMENS

up to 2
NIGHTS
DURATION

GS32V30
GAMA SONIC
BATTERY

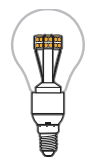

Includes Part
#C37WW10W
(Bright white sold
separately)



Integrated PIR
motion sensor



Part #	Dimensions	UPC	Wgt	LED Color	Lamp Color
94B001	8L x 9.5W x 90H	853153005725	12.5	Warm White (2700K)	Black
94B002	8L x 25W x 87H	853153005732	19.5		
94B003	25L x 25W x 87H	853153005749	26.5		
94B033	8L x 9.5W x 15H	854433001505	7		White
94B233	8L x 9.5W x 15H	185455000208			Black
94BS50033	8L x 9.5W x 15H	859641008001	4.4		



Aria Solar Light

- Powered by efficient monocrystalline solar panels
- Automatic dusk to dawn operations
- Cast-aluminum weather resistant structure
- Patents #9458970, #D629950
- 5.6W trapezoid tempered glass solar panel

150
LUMENS

up to 12
HOURS
DURATION

GS32V30
GAMA SONIC
BATTERY



 Includes Part #A60WW20W (Bright white sold separately)

Gama Sonic's Aria Solar Wall Light is a beautiful, modern solar wall light designed to brighten any outdoor space. The Aria's 4 solar panels will maximize solar charge for longer light duration. There is no wiring required with this simple installation so your home's walkways, entryway, and backyard will quickly be illuminated with high-quality, solar lighting LED output with automatic dusk-to-dawn operation.

Part #	Dimensions	UPC	WgtK	LED Color	Lamp Color
66B50010	11.25L x 9.38W x 17.38H	859641008384	6	Warm White (2700K)	Black
66B50001	16.75L x 9.375W x 99H	859641008810	17.2		
66B50002	9.375L x 26W x 99H	859641008810	22.6		



The Royal Bulb Solar Lamp Series is constructed of weather resistant, powder-coated brushed bronze cast aluminum and rain glass panes. The lights feature an attractive design inspired by New Orleans architecture. It incorporates our cutting-edge GS Solar LED Light bulb technology and provides 360-degree illumination. Now available with 2.5X larger solar panels for more charging power.

Royal Bulb Solar Light Brushed Bronze

IMPROVED: 60% More Charging Power

- Automatic dusk to dawn operation
- Cast-aluminum weather resistant structure
- Rain glass panes
- Patents #7172307, #9458970
- 6W trapezoid tempered glass solar panel

150
LUMENS



up to 2
NIGHTS
DURATION

2X 
GS32V15
GAMA SONIC
BATTERY

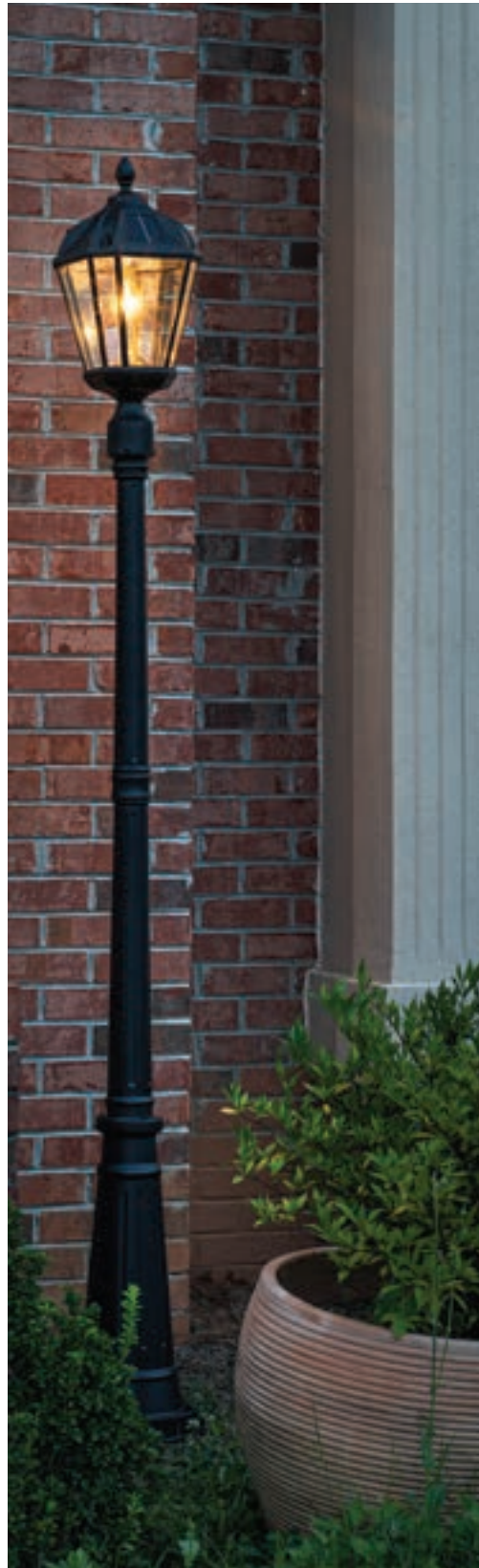

Part #	Dimensions	UPC	Wgt	LED Color	Lamp Color
98B110	12.5L x 8.75W x 21H	859641007059	7	Warm White (2700K)	Brushed Bronze
98B111	8.75L x 8.75W x 23H	859641007042	9.5		
98B112	8.75L x 8.75W x 18H	859641007035	9.5		
98B101	8.75L x 8.75W x 87H	859641007011	15		

Royal Bulb Solar Light Black



IMPROVED: 60% More Charging Power

- Automatic dusk to dawn operation
- Cast-aluminum weather resistant structure
- Beveled glass panes
- Patents #7172307, #9458970
- 6W trapezoid tempered glass solar panel

150
LUMENS

up to 2
NIGHTS
DURATION

2X 
GS32V15
GAMA SONIC
BATTERY

 Includes Part
#A50WW10W
(Bright White
solar separately)

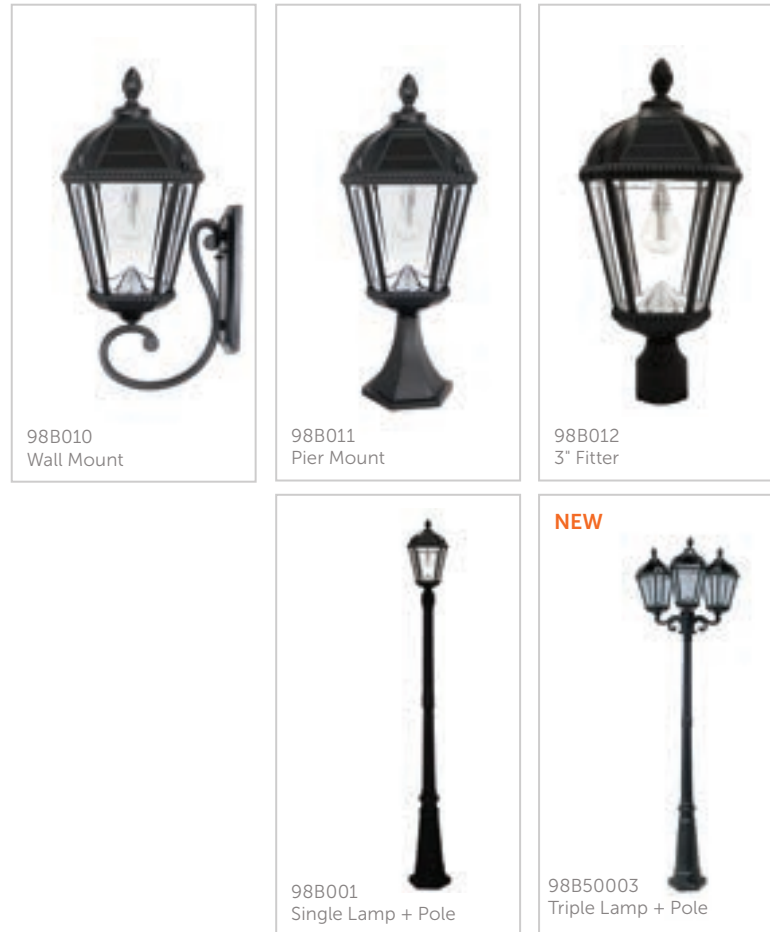

Part #	Dimensions	UPC	Wgt	LED Color	Lamp Color
98B011	8.75L x 8.75W x 23H	859641007400	7.5	Warm White (2700K)	Black
98B012	8.75L x 8.75W x 18H	853153005930	6.5		
98B010	12.5L x 8.75W x 21H	859641007417	9.5		
98B001	8.75L x 8.75W x 23H	859641007400	7.5		
98B50003	27L x 27W x 89H	185455000581	30		

Royal Bulb Solar Light Weathered Bronze



IMPROVED: 60% More Charging Power

- Automatic dusk to dawn operation
- Cast-aluminum weather resistant structure
- Beveled glass panes
- Patents #7172307, #9458970
- 6W trapezoid tempered glass solar panel

150
LUMENS

up to 2
NIGHTS
DURATION

2X 
GS32V15
GAMA SONIC
BATTERY

 Includes Part
#A50WW10W
(Bright white
sold separately)

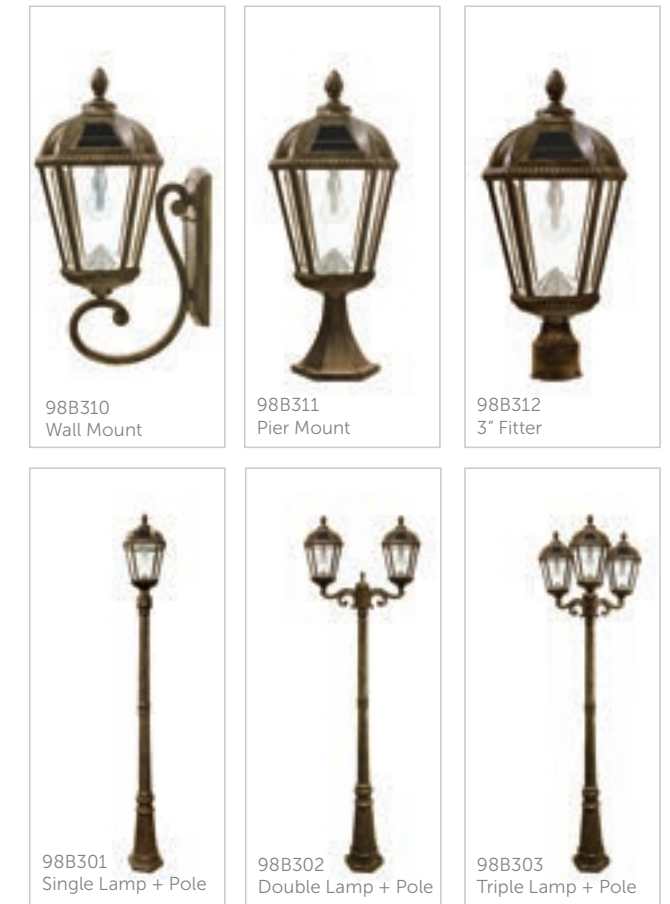

Part #	Dimensions	UPC	Wgt	LED Color	Lamp Color
98B310	12.5L x 8.75W x 21H	853153005923	9.5	Warm White (2700K)	Weathered Bronze
98B311	8.75L x 8.75W x 23H	853153005916	7.5		
98B312	8.75L x 8.75W x 18H	853153005909	6.5		
98B301	8.75L x 8.75W x 87H	853153005879	15		
98B302	8.75L x 27W x 89H	853153005886	24		
98B303	27L x 27W x 89H	853153005893	30		

Polaris Solar Light



- Coastal approved
- IP65 - weather resistant rating
- ABS rigid resin with UV protection
- Automatic dusk to dawn operation
- Patents #7172307, #9458970
- 4.2W tempered glass solar panel

130
LUMENS

up to 12
HOURS
DURATION

2X 
GS32V15
GAMA SONIC
BATTERY

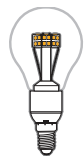
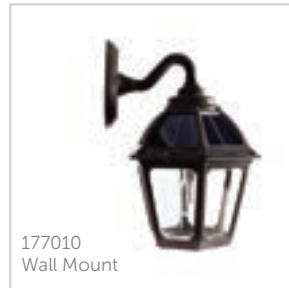

Includes Part #A50WW10W (Bright white sold separately)

Part #	Dimensions	UPC	Wgt	LED Color	Lamp Color
177B50002	9.13L x 27W x 91.88H	859641007974	15	Warm White (2700K)	Black
177010	10L x 9.5W x 12H	859641007219	4.2		

Baytown II Bulb Solar Lamp



- Automatic dusk to dawn operation
- Weather resistant structure
- Rigid ABS resin exterior
- Patents #7172307, #9458970
- 3.2W tempered glass solar panel

130
LUMENS

up to 12
HOURS
DURATION

GS32V15
GAMA SONIC
BATTERY

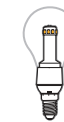

Includes Part #A50WW10W (Bright white sold separately)



100 Lumens
2W panel
C-37 Bulb

Part #	Dimensions	UPC	Wgt	LED Color	Lamp Color
105BSG01	9.5L x 12W x 77H	185455000109	11	Warm White (2700K)	Black
105BP250040	5L x 9.5W x 15.5H	859641007660	8.5		
105B033	9.5L x 9.5W x 19H	853153005022	5		
105BSG21	9.5L x 12W x 77H	859641007813	11		White
105BP250240	5L x 9.5W x 15.5H	859641007783	1.6		
105B233	9.5L x 9.5W x 19H	859641007806	6		

Grand Prairie Bulb Solar Light



- Automatic dusk to dawn operation
- Cast-aluminum weather resistant structure
- Clear glass panes
- Patents #7172307, #9458970
- 3W tempered glass solar panel

150
LUMENS

up to 2
NIGHTS
DURATION

GS32V30
GAMA SONIC
BATTERY

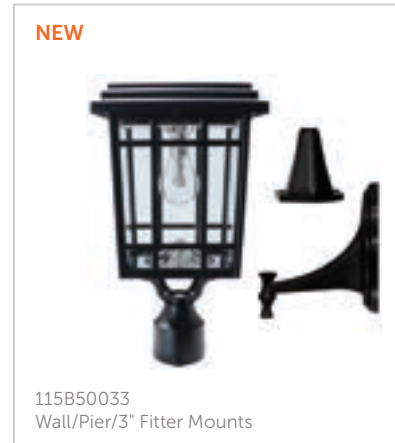

Part #	Dimensions	UPC	Wgt	LED Color	Lamp Color
115B50033	8.625L x 8.625W x 15.75H	859641007394	5.8	Warm White (2700K)	Black

Pagoda Bulb Solar Lamp



New & Improved 80% More Charging Power

- Automatic dusk to dawn operation
- Cast-aluminum weather resistant structure
- Clear glass panes
- Patents #7172307, #9458970
- 6.8W trapezoid tempered glass solar panel

180
LUMENS

up to 2
NIGHTS
DURATION

GS32V30
GAMA SONIC
BATTERY



Part #	Dimensions	UPC	Wgt	LED Color	Lamp Color
104B033	14L x 11W x 22H	859641007325	12	Warm White (2700K)	Black
104B001	11L x 11W x 87H	859641007332	18		

Orion Solar Light



- Morph technology
- Powered by efficient monocrystalline solar panels
- Automatic dusk to dawn operation
- Rigid resin weather resistant structure
- Exterior low/off/high switch
- Patent #9458970
- 4W solar panel

150
LUMENS

up to 2
NIGHTS
DURATION

2X 
GS32V15
GAMA SONIC
BATTERY



123010
Wall Mount

123BM50001
Lamp + Pole

123BM50003
Triple Lamp + Pole

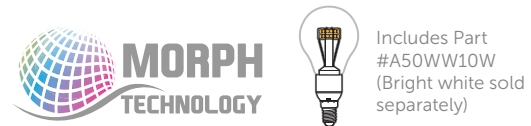

Part #	Dimensions	UPC	Wgt	LED Color	Lamp Color
123010	8.5L x 10.5W x 13H	185455000574	3.4	Warm White (2700K)	Black
123BM50001	19L x 9W x 94.63H	859641007967	10.4		
123BM50003	23.75L x 26.25W x 94.63	859641007981	14		

Aspen Solar Light



- Powered by efficient monocrystalline solar panels
- Automatic dusk to dawn operation
- Cast-aluminum weather resistant structure
- Rain glass panes
- Exterior low/off/high switch
- Patent #9458970
- 3W tempered glass solar panel

120
LUMENS

up to 2
NIGHTS
DURATION

2X 
GS32V15
GAMA SONIC
BATTERY

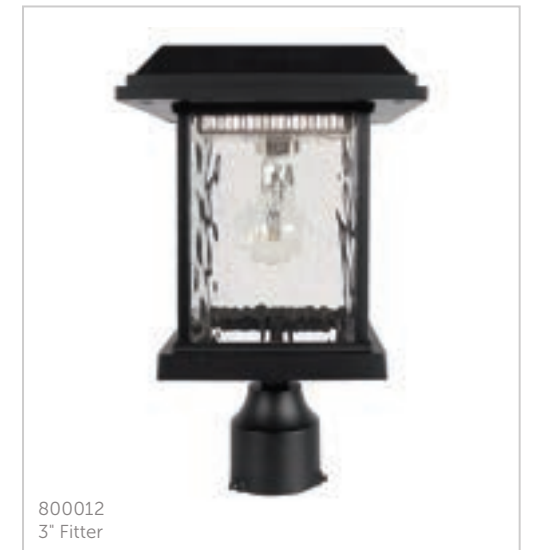

800012
3" Fitter



Part #	Dimensions	UPC	Wgt	LED Color	Lamp Color
800012	9L x 9W x 15H	859641007134	7	Warm White (2700K)	Black

Imperial Trio Bulb Solar Post Light



- Morph Technology
- Automatic dusk to dawn operation
- Cast-aluminum weather resistant structure
- Beveled glass panes
- Patent #9458970
- 8.8W trapezoid tempered glass solar panel

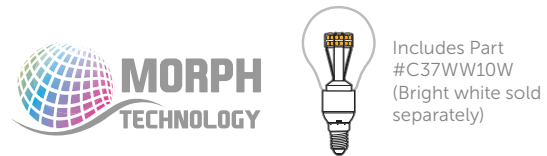
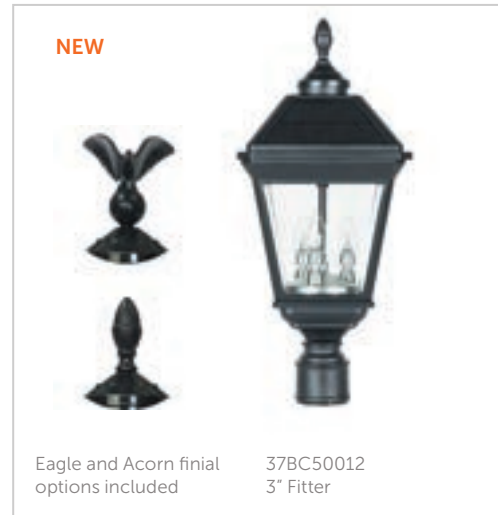

180 LUMENS | up to 2 NIGHTS DURATION | 2X GS32V30 GAMA SONIC BATTERY

Part #	Dimensions	UPC	Wgt	LED Color	Lamp Color
37BC50012	10.75L x 10.75W x 24.25H	185455000338	9.8	Warm White (2700K)	Black

Halo Solar Post Light



- Powered by efficient monocrystalline solar panels
- Automatic dusk-to-dawn operation
- Cast-aluminum weather-resistant structure
- IP65 - weather resistant rating
- Dual color - bright white/warm white
- 7.5W tempered glass solar panel



300 LUMENS | up to 2 NIGHTS DURATION | 2X GS32V15 GAMA SONIC BATTERY

Part #	Dimensions	UPC	Wgt	LED Color	Lamp Color
315i90012	10L x 10W x 14.63H	185455000697	6.2	Bright White (6000K)	Black



Contemporary Square Solar Post Light w/ Timer

- Powered by efficient monocrystalline solar panels
- Automatic dusk to dawn operation
- Corrosion resistant powder coated cast aluminum
- 3 color temperature options: Warm White (3000K) / Natural White (4000K) / Bright White (5000K)
- 14W tempered glass solar panel
- 2 mounting options: center mount and side mount
- Timer feature allows 4-8 hours of duration or dusk to dawn operation



500
LUMENS

2-4
NIGHTS
DURATION

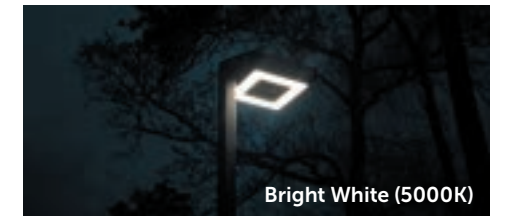
GS32V15A
GAMA SONIC
BATTERY

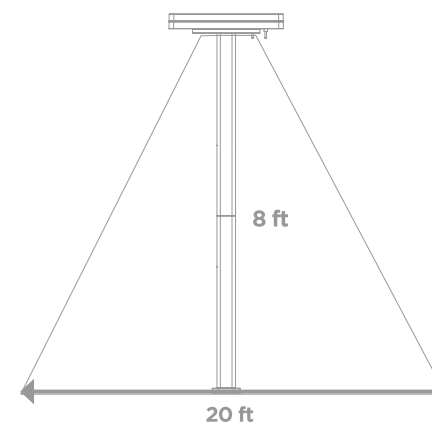
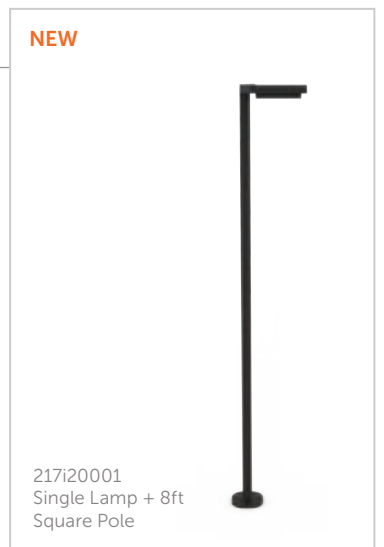

2 Mounting Options



TIMER



4,5,6,7,8 hours duration
or 0 for dusk to dawn
operation

Introducing Gama Sonic's Contemporary Square Solar Lamp Post with Built in Timer and accompanying 8ft modern square pole, designed to transform outdoor spaces with its radiant 500 lumen output. Perfect for parks, playgrounds, and shopping lots, this solar post light has a versatile illumination that enhances safety and ambiance alike. With three color temperature settings to suit any environment, paired with its sleek, modern design, this contemporary combination seamlessly blends functionality with style, illuminating your outdoor space with both efficiency and elegance.

Part #	Dimensions	UPC	Wgt	LED Color	Lamp Color
217i20001	17.5L x 12.25W x 98.75H	859641008780	19	3000K/4000K/5000K	Black
217i20012	12.25L x 12.25W x 5H	859641008797	7.4		

Eclipse Downlight Solar Wall Light



- Powered by efficient monocrystalline solar panels
- Automatic dusk-to-dawn operation
- Cast-aluminum weather-resistant structure
- IP65 - weather resistant rating
- 3 color temperature options: 3000K / 4000K / 5000K
- Exterior low/off/high switch
- 7W tempered glass solar panel

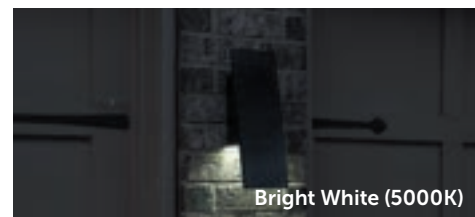
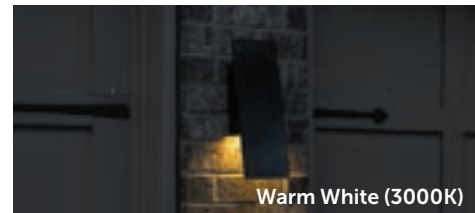

200 LUMENS
up to 2 NIGHTS DURATION
2X **GS32V30** GAMA SONIC BATTERY

Part #	Dimensions	UPC	Wgt	LED Color	Lamp Color
56iM50010	5.25L x 5.25W x 15H	185455000635	3.4	Warm White (3000K) + Natural White (4000K) + Bright White (6000K)	Black

Eclipse Backlight Solar Wall Light



- Powered by efficient monocrystalline solar panels
- Automatic dusk-to-dawn operation
- Cast-aluminum weather-resistant structure
- IP65 - weather resistant rating
- 3 color temperature options: 3000K / 4000K / 5000K
- Exterior low/off/high switch
- 7W tempered glass solar panel

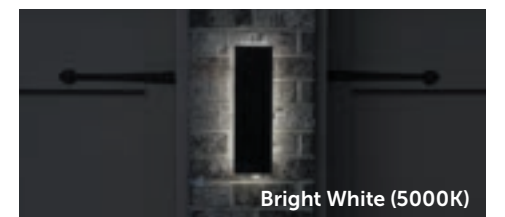

200 LUMENS
up to 2 NIGHTS DURATION
2X **GS32V15** GAMA SONIC BATTERY

Part #	Dimensions	UPC	Wgt	LED Color	Lamp Color
59iM50010	2.83L x 4.75W x 15.75H	185455000604	4	Warm White (3000K) + Natural White (4000K) + Bright White (6000K)	Black

Cottage Solar Barn Light



- Morph Technology
- Powered by efficient monocrystalline solar panels
- Automatic dusk to dawn operation
- Cast-aluminum weather resistant structure
- Patents #9458970
- 8.4W solar panel

250
LUMENS

up to 3
NIGHTS
DURATION

2x
GS32V30
GAMA SONIC
BATTERY



Includes Part #A60WW20W (Bright white sold separately)

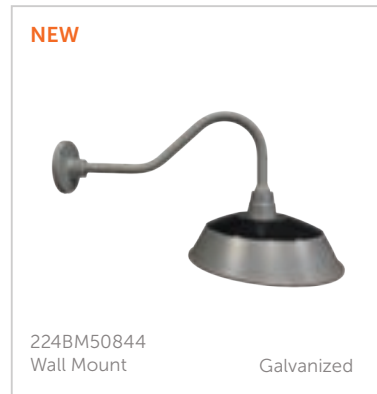
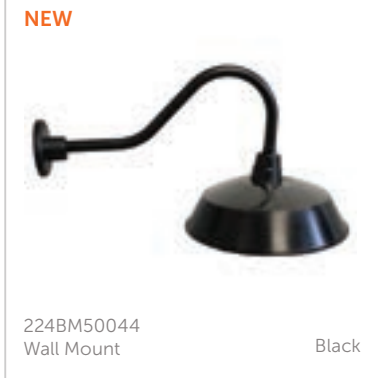

Part #	Dimensions	UPC	Wgt	LED Color	Lamp Color
224BM50044	28L x 14.5W x 15H	859641008988	5.2	Warm White (2700K)	Black
224BM50244		859641008100			White
224BM50844		859641008995			Galvanized

Carriage Solar Barn Light



- Morph Technology
- Powered by efficient monocrystalline solar panels
- Automatic dusk to dawn operation
- Resin weather resistant structure
- Patent #9458970
- 7.2W tempered glass solar panel

150
LUMENS

up to 2
NIGHTS
DURATION

2X
GS32V15
GAMA SONIC
BATTERY



Includes Part #D46WW05W (Bright white sold separately)

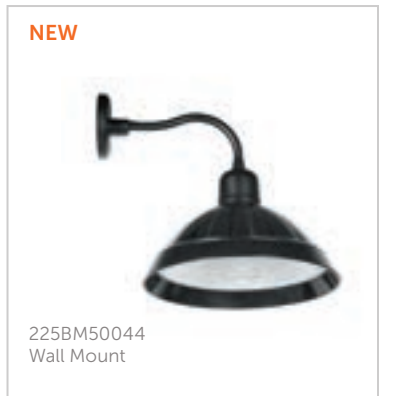

Part #	Dimensions	UPC	Wgt	LED Color	Lamp Color
225BM50044	14L x 11.25W x 11.63H	185455000277	2.2	Warm White (2700K)	Black

Modern Farmhouse Solar Wall Light



- Powered by efficient monocrystalline solar panel
- Automatic dusk to dawn operation
- Cast-aluminum weather resistant structure
- Glass panes
- Low/off/high switch
- 3.8W tempered glass solar panel

80
LUMENS

up to 2
NIGHTS
DURATION

GS32V30
GAMA SONIC
BATTERY



Includes Part
#T20LWW04W

Part #	Dimensions	UPC	Wgt	LED Color	Lamp Color
130B50010	6.13L x 7.75W x 14.5H	185455000116	5.8	Warm White (2700K)	Black

Novaedge Solar Light

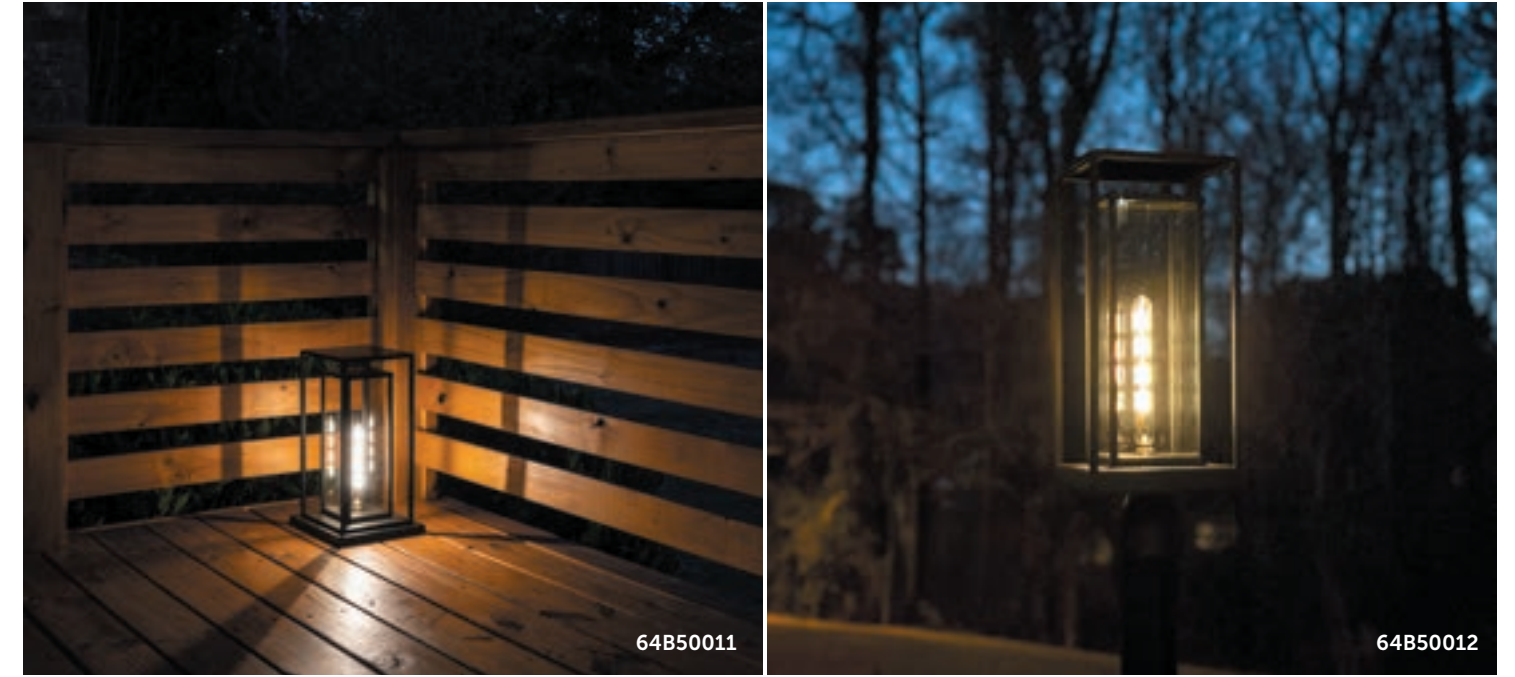

- Powered by efficient monocrystalline solar panels
- Automatic dusk-to-dawn operation
- Cast-aluminum weather-resistant structure
- IP65 - weather resistant rating
- Exterior low/off/high switch
- 5W tempered glass solar panel

200
LUMENS

up to 2
NIGHTS
DURATION

GS32V30
GAMA SONIC
BATTERY

Includes Part
#T20LWW04W

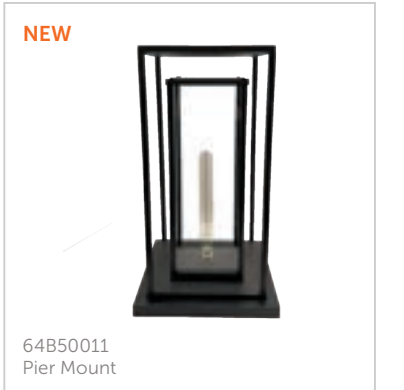

Part #	Dimensions	UPC	Wgt	LED Color	Lamp Color
64B50011	9.5L x 9.5W x 16.94H	854433001208	6.6	Warm White (2700K)	Black
64B50012	7.88L x 7.88W x 20.38H	185455000598	7		

Solar Coach Light



- Powered by efficient monocrystalline solar panel
- Automatic dusk to dawn operation
- Cast-aluminum weather resistant structure
- Exterior low/off/high switch
- Patent #9458970
- 1W tempered glass solar panel

60 LUMENS
up to 12 HOURS DURATION
GS32V15 GAMA SONIC BATTERY

Part #	Dimensions	UPC	Wgt	LED Color	Lamp Color
1BE40010	7L x 5.5W x 7.5H	859641007707	2	Warm White (2400K)	Black
1BE40810		859641008360			Grey

Solar Address Wall Plaque Light with Ground Stakes

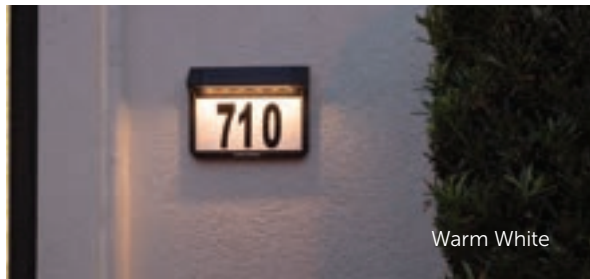

- 4pcs each of 0-9 | 1 each of A,B,C,D,E
- Dual color - bright white/warm white
- Automatic dusk to dawn operations
- Cast aluminum finish weather resistant structure
- Powered by efficient monocrystalline solar panels
- 1.5W solar panel

15 LUMENS
up to 12 HOURS DURATION
SB37V08 GAMA SONIC BATTERY

Part #	Dimensions	UPC	Wgt	LED Color	Lamp Color
81i90010	2.25L x 10.68W x 8.13H	59641008254	1.2	Bright White (6000K) + Warm White (2700K)	Black

Architectural Solar Wall Accent Light w/ Motion Sensor

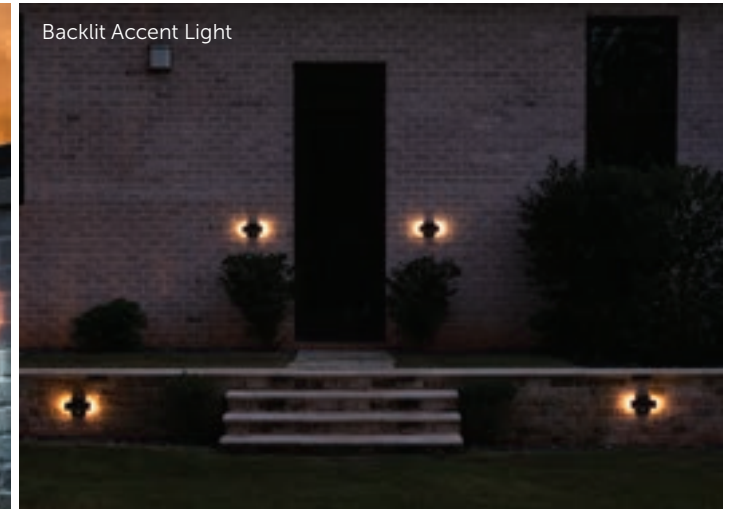

- Cast-aluminum weather resistant structure
- Powered by efficient monocrystalline solar panel
- Exterior low/off/high switch
- Automatic dusk to dawn operation
- Bright white (6000K) motion activated security light
- Warm white (2700K) backlit accent light
- 1.2W tempered glass solar panel

120 LUMENS
up to 18 HOURS DURATION
GS32V15 GAMA SONIC BATTERY



Part #	Quantity	Dimensions	UPC	Wgt	LED Color	Lamp Color
4iP2S50410	2 Pack	3L x 8W x 5H	859641008070	1.2	Warm White (2700K)	Bronze
4iP2S50010	2 Pack		859641008056			Black

Contemporary Square Solar Path Light



Warm White



Bright White

- Dual color - bright white/warm white
- Powered by efficient monocrystalline solar panels
- Automatic dusk to dawn operation
- Cast-aluminum weather resistant structure
- Exterior High/Off/Low switch
- 2W tempered glass solar panel
- 6x more charging power than an average solar light



117i90480
Bronze

117i90080
Black

80
LUMENS

up to 2
NIGHTS
DURATION

GS37V20FLT
GAMA SONIC
BATTERY

Part #	Dimensions	UPC	Wgt	LED Color	Lamp Color
11790080	6.13L x 6.13W x 26.75H	859641007752	2.2	Bright White (6000K) + Warm White (2700K)	Black
11790480		859641008124			Bronze

Sentry Modern Pathway Solar Light Set of 2



- Powered by efficient monocrystalline solar panels
- Automatic dusk to dawn operations
- Cast-aluminum finish weather resistant structure
- 2 Mounting options: flat surface mount and ground stake mount
- 1.2W tempered glass solar panel



92iP260082
Stake and Flat Mount

60
LUMENS

up to 2
NIGHTS
DURATION

GS32V15
GAMA SONIC
BATTERY

Part #	Dimensions	UPC	Wgt	LED Color	Lamp Color
92iP260082	4.75L x 3W x 24H	859641008483	2	Bright White with White Accent	Black

Solar Garden Light Shepherd Hook



- Morph technology
- Powered by efficient monocrystalline solar panels
- Automatic dusk to dawn operation
- Cast-aluminum pole
- Rigid resin weather resistant frame
- Patent #9458970
- 4.8W solar panel
- 8x more charging power than the average solar light



148101
Shepherd Hook



Includes Part #C37WW10W (Bright white sold separately)

80
LUMENS

up to 12
HOURS
DURATION

GS32V15
GAMA SONIC
BATTERY

Part #	Dimensions	UPC	Wgt	LED Color	Lamp Color
148101	7L x 7W x 21.5H	859641007684	2.8	Warm White (2700K)	Black

Tri-Color Progressive Solar Spotlight



100
LUMENS

up to 10
HOURS
DURATION

GS32V30
GAMA SONIC
BATTERY

- Cast-aluminum weather resistant structure
- 2 mounting options
- Remote solar panel
- Exterior on/off switch
- 2W tempered glass solar panel
- Detachable panel with 8 ft cord
- Comes with 12 ft extension cord
- 3 color temperature options: 3000K / 4500K / 5000K

Part #	Dimensions	UPC	Wgt	LED Color	Lamp Color
103i90090	7L x 5W x 15H	185455000789	4.2	Warm White (3000K) + Natural White (4000K) + Bright White (6000K)	Black

Dual Color Solar Flood Light



- IP65 - weather resistant rating
- Automatic dusk to dawn operation
- 20 bright SMD LEDs
- Cast-aluminum weather resistant structure
- 2 mounting options
- Exterior low/off/high switch
- 4W tempered glass solar panel
- Detachable panel with 12ft cord
- Dual color - bright white/warm white



250
LUMENS

Up to 20
HOURS
DURATION

2X
GS37V40
GAMA SONIC
BATTERY

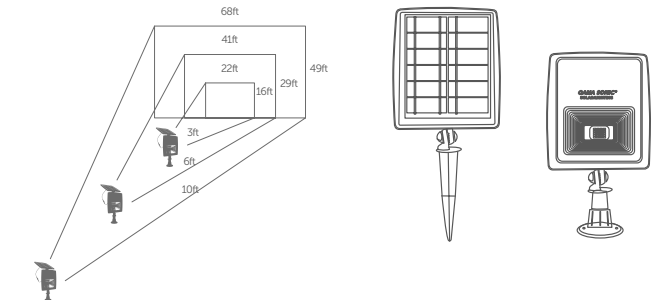

Part #	Dimensions	UPC	Wgt	LED Color	Lamp Color
203001	2.5L x 8W x 18H	859641007165	6	Bright White (6000K) + Warm White (2700K)	Black

Luxor Stainless Steel Bollard Solar Light

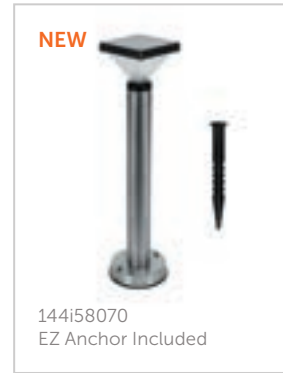

- Powered by efficient monocrystalline solar panels
- Automatic dusk to dawn operation
- Weather resistant resin with stainless steel bollard
- 1.6W tempered glass solar panel

Part #	Dimensions	UPC	Wgt	LED Color	Lamp Color
144i58070	5L x 5W x 20.25H	859641008964	1.85	Warm White (2700K)	Black

Luxor Solar Pathway Light Set of 2



- Powered by efficient monocrystalline solar panels
- Automatic dusk to dawn operation
- Cast-aluminum weather resistant structure
- 1.6W tempered glass solar panel

Part #	Dimensions	UPC	Wgt	LED Color	Lamp Color
146iP250080	4.375L x 4.375W x 23H	859641008971	1.6	Warm White (2700K)	Black

Luxor Solar Post Cap Light Set of 2



- Powered by efficient monocrystalline solar panels
- Automatic dusk to dawn operation
- Rigid ABS Resin exterior
- 1.2W tempered glass solar panel

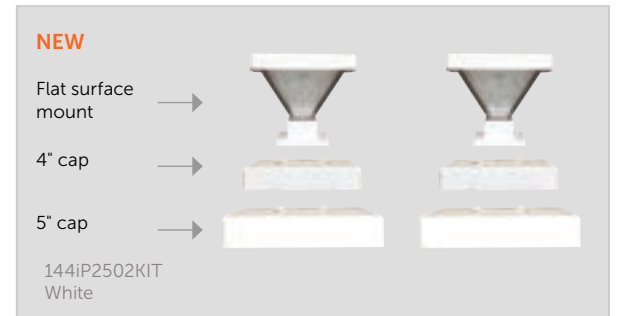

Part #	Quantity	Dimensions	UPC	Wgt	LED Color	Lamp Color
144iP2500KIT	2 Pack	4.375L x 4.375W x 4H	859641008940	0.6	Warm White (2700K)	Black
144iP2502KIT	2 Pack		859641008957			

Gothic Solar Post Cap Light Set of 2



Black



White

- Powered by efficient monocrystalline solar panels
- Automatic dusk to dawn operation
- Exterior low/off/high switch
- Dual color temperature: switch between warm white (3100K) or bright white (6000K)
- Rigid ABS resin exterior
- Patent #7172307
- 2.65W tempered glass solar panel

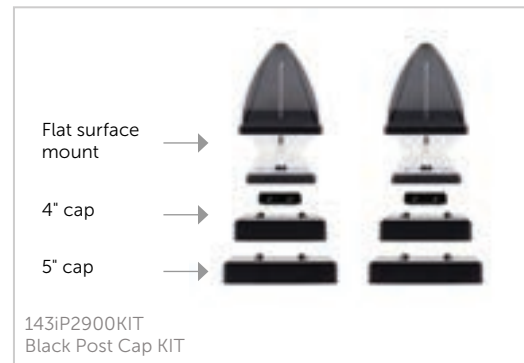

40 LUMENS

up to 2 NIGHTS DURATION

GS32V15 GAMA SONIC BATTERY

Part #	Quantity	Dimensions	UPC	Wgt	LED Color	Lamp Color
143iP2900KIT	2 Pack	3.6L x 3.6W x 7H	859641007363	1.56	Bright White (6000K) + Warm White (2700K)	Black
143iP2902KIT	2 Pack		85964100737			

Luna II Solar Post Cap/Pier Mount Light Set of 2



- Powered by efficient monocrystalline solar panels
- Automatic dusk to dawn operation
- 1.2W tempered glass solar panel
- Patent #7172307, 9458970
- 2 mounting options: 4x4 fence post cap mount and pier mount

50 LUMENS

up to 2 NIGHTS DURATION

GS32V15 GAMA SONIC BATTERY



Includes Part #D46WW05W (Bright white sold separately)

Part #	Quantity	Dimensions	UPC	Wgt	LED Color	Lamp Color
84BP250011	2 Pack	5L x 5W x 9H	859641008834	2.4	Warm White (2700K)	Black

Accessories

Batteries

Gama Sonic® uses the highest quality batteries and technology to power our solar lights. Our batteries are strategically matched with a solar lamp to maximize its duration and brightness. As technology continues to be increasingly important in the growing solar lighting world, we set the industry standard on quality battery solutions. We only use specially designed products that are packed, sealed, and use an external harness to eliminate corrosion and provide the superior charging and powering of the light our customers expect.

To learn more visit gamasonic.com

New turtle safe bulbs available*

- A50TL10W
- A60TL20W
- C37TL10W

GS Solar LED Light Bulb

Patent #945897

Works only with Gama Sonic bulb series fixtures

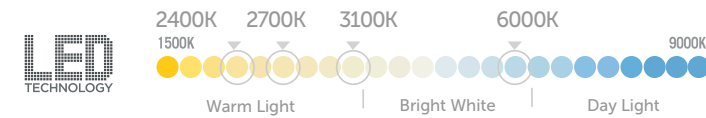

 <p>A50WW10W A50BW10W A50TL10W* 11 LEDs 220mA/0.7W</p>	 <p>A60BW30W 27 LEDs 1A/3.5W</p>	 <p>A60WW20W A60BW20W A60TL20W* 11 LEDs 440mA/1.5W</p>
 <p>C37WW10W C37BW10W C37TL10W* 11 LEDs 600mA/2W</p>	 <p>A60WW20W-DIR A60BW20W-DIR 4+7 LEDs 440mA/1.5W</p>	 <p>T45WW10W Filament Style 220mA/0.75W</p>
 <p>F30WW05W Simulated Flame Style 40 LEDs 220mA/0.75W</p>	 <p>D46WW05W 6 LEDs 220mA/0.75W</p>	<p>NEW</p>  <p>T20LWW04W Tubular Style</p>

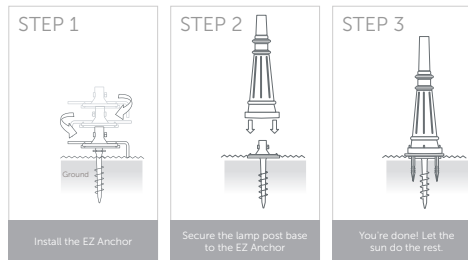

EZ-Anchor Solar Lamp Post Anchor Kit

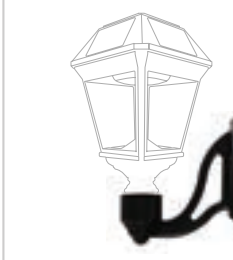

NOTE: 30001 EZ-Anchor Lamp Post Base is built to support ONLY single lamps on a Gama Sonic® Decorative or Imperial Post. DO NOT USE to support multi-lamp products.

<p>NEW</p> <p>Trio Bulb Candelabra Kit</p>  <p>3BCKIT80</p>	<p>Pier Base Mount for 3" Post Top Mounts</p>  <p>PBM00</p>	<p>Universal Wall Bracket</p>  <p>97NWKITO</p>
---	---	---

Part #	UPC	Pkg. Size (in)	Wgt
30001	185455000024	26L x 12W x 12H	6
97NWKITO	185455000055	9L x 8W x 6H	1.5
PBM00	859641007387	6.25L x 6.25W x 2.25H	0.4
3BCKIT80	185455000345	5.38L x 5.38W x 9.25H	1



Posts

- All our poles fit most 3" post top fixtures
- Matte finish cast aluminum weather resistant poles

Commercial Posts

 <p>CP65F0 6.5 FT.</p>	 <p>CP8F0 8 FT.</p>	 <p>CP10F0 10 FT.</p>	 <p>**DBP10F0 10 FT.</p>
---	--	--	---

** Requires freight shipping

Residential Posts

 <p>DPEZ5F0 Black 64"</p>	 <p>97SP0 Black 78"</p>	 <p>DP55F0 Black 68"-79"</p>	 <p>DP55F2 White 68"-79"</p>
---	---	--	--

Part #	UPC	Pkg. Size (in)	Wgt
CP65F0	853153005855	11.6L x 15.5W x 29H	20
CP8F0	853153005756	11.6L x 15.5W x 38H	22
CP10F0	853153005763	11.6L x 15.5W x 48.5H	25
DP55F2	185455000239	9L x 11W x 24H	8
DP55F0	185455000185		
97SP0	185455000031	12.5L x 10W x 32H	11
DPEZ5F0	859641008148	9.75L x 25.13W x 13H	8
DBP10F0	859641008353	3L x 3W x 143.25H	19.6

GAMA SONIC[®]
SOLAR LIGHTING

Gama Sonic USA Inc.

6185-F Jimmy Carter Boulevard
Norcross, Georgia 30071 USA

info@gamasonic.com

Tel: 1 800 835 4113
Fax: 1 800 835 4173